

OTR PLUS



FLEET EQUIPMENT CORPORATION
THE MOST TRUSTED NAME IN TIRE TRUCKS.
Franklin Lakes, NJ ■ 800.631.0873 ■ www.fectrucks.com





The OTR Plus service vehicle for a tandem chassis. A 22017 Crane with optional TP145PR Tire Positioner on this heavy-duty unit will get the job done. Your customers demand the best, so should you.



Hose reels commonly placed in slew box on left side. 1/2" X 50' and 3/8" X 50' heavy duty reels with hose end guard, Optional airing station for easy tire inflation is available.



H150 air compressor with PTO/hydraulic drive. 127 CFM with a 23 or 38 gal. tank.



Optional rear step and grab handle for easy access to the bed.



Tire Life tank and O-Ring rack.

22017 Crane	
220,000 ft. lbs. rating	
Crane Capacity Rating	22,000 lbs. at 10'
Maximum Reach	17'
Crane Weight	9500 lbs.
Chassis RBM Required	2,838,000 in.lbs.



Cross-body block basket with a fold-down side and tool boxes available depending on chassis length and configuration. Sahara air dryer also shown.



Tool drawers available for carrying small parts and tools.



Optional rear fold-down block basket.

CRANE FEATURES

- Manual crane controls on left side of the vehicle.
- Rack and pinion rotation system offers rugged durability and simplicity.
- Load holding valves on all lift cylinders, chrome plated cylinder rods and tube walls.
- Center mounted crane offers better weight distribution to chassis suspension.
- Crane nose will accept push bar.
- Self lubricating bearing surface on all slide tubes.
- Heavy duty PTO and hydraulic pump.

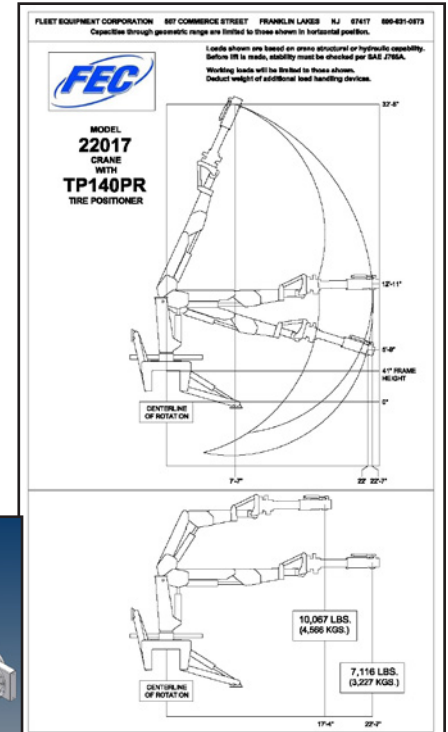

Optional fully proportional radio remote control with unique manual lever backup in case remote system is lost or damaged.



Optional backup camera.



10,000 psi Jack Assist available.

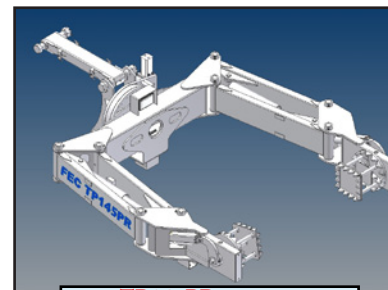

TP145PR
 Tire Positioner
 Maximum Open 146"
 Minimum Closed 47" (with adapters)

FLEET EQUIPMENT CORPORATION
THE MOST TRUSTED NAME IN TIRE TRUCKS.
 Franklin Lakes, NJ ■ 800.631.0873 ■ www.fectrucks.com

