

# MIDDI



**FLEET EQUIPMENT CORPORATION**  
**THE MOST TRUSTED NAME IN TIRE TRUCKS.**  
Franklin Lakes, NJ ■ 800.631.0873 ■ [www.fectrucks.com](http://www.fectrucks.com)





The Middi OTR service vehicle is 15' long with a flat bed or as a haul body with 41" tall sides. Built for Fleet Service and OTR work, this heavy-duty unit is available with choice of a 2000 Crane with optional TP108P Tire Positioner or an 8716 Crane that stows in a folded position behind the cab. Many of the features from this unit are found on the largest OTR service units. Aluminum and Steel construction allows us to reduce weight without sacrificing strength. Your customers demand the best, so should you.



H65 air compressor with PTO/hydraulic drive. 60 CFM with a 23 or 38 gal. tank.  
or  
H140 air compressor with PTO/hydraulic drive. 75 CFM with a 23 or 38 gal. tank.

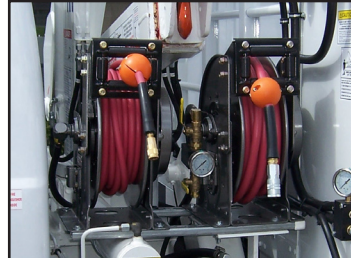

Hose reels commonly placed on left side above the crane controls. 1/2" X 50' and 3/8" X 50' heavy duty reels with hose end guard.

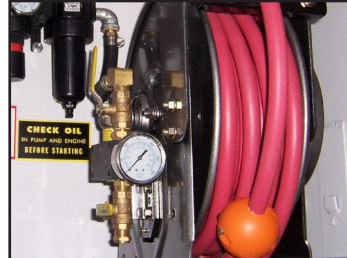

Optional airing station for easy tire inflation.

2000 Crane	
84,000 ft. lbs. rating	
Crane Capacity Rating	8,400 lbs. at 10'
Maximum Reach	14'-10"
Crane Weight	2610 lbs.
Chassis RBM Required	1,090,000 in.lbs.

8716 Crane	
96,000 ft. lbs. rating	
Crane Capacity Rating	9,600 lbs. at 10'
Maximum Reach	16'
Crane Weight	3800 lbs.
Chassis RBM Required	1,240,000 in.lbs.



2000 lb. liftgate with heavy duty steel frame and aluminum platform. Self locking two-point spring loaded lock system locks platform closed when stored for travel. Optional self locking tire stacking rack on platform.



Tool drawers available for carrying small parts and tools.

- ### CRANE FEATURES
- Manual crane controls on left side of the vehicle.
  - Rack and pinion rotation system offers rugged durability and simplicity.
  - Load holding valves on all lift cylinders, chrome plated cylinder rods and tube walls.
  - Center mounted crane offers better weight distribution to chassis suspension.
  - Crane nose will accept push bar.
  - Self lubricating bearing surface on all slide tubes.
  - Heavy duty PTO and hydraulic pump.

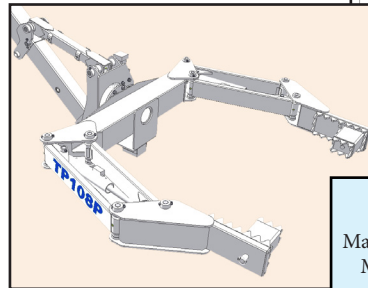

**TP108P**  
Tire Positioner  
Maximum Open 108-1/2"  
Minimum Closed 29"  
2000 Crane only

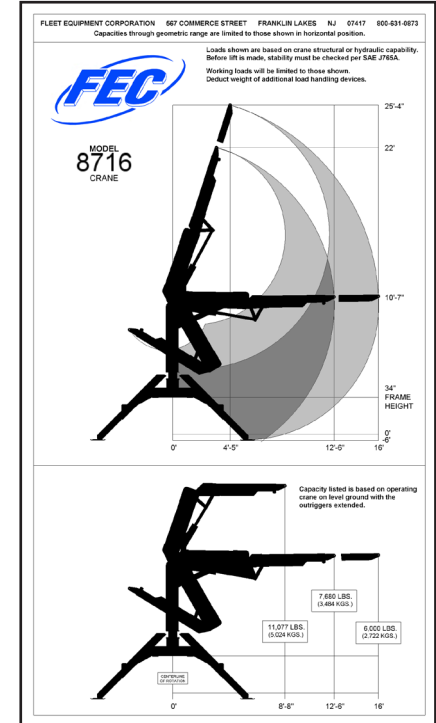
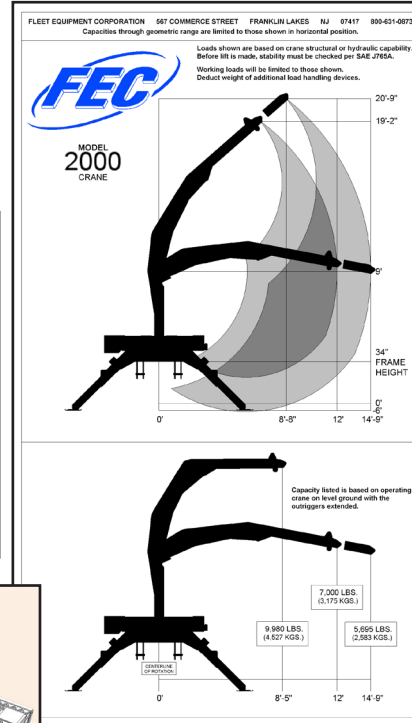

7-pin trailer plug available for testing trailer lights. Optional backup camera for safety while reversing.



Optional radio remote control with unique manual lever backup in case remote system is lost or damaged.

**FLEET EQUIPMENT CORPORATION**  
**THE MOST TRUSTED NAME IN TIRE TRUCKS.**  
Franklin Lakes, NJ ■ 800.631.0873 ■ www.fectrucks.com

