

RAM JET PICK UP CONVERSION SYSTEM

OPTIONAL SIDE RACKS



BOXES MOUNTED ON BED RAILS ARE OPTIONAL



THE RAM JET CAN BE DROP SHIPPED TO YOUR LOCATION FOR INSTALLATION BY YOUR PERSONNEL

- ALUMINUM LEFT FRONT TOOL COMPARTMENT WITH BUILT IN TOOL SHELF.
- ALUMINUM RIGHT FRONT TOOL COMPARTMENT.
- STEEL CENTER AIR COMPRESSOR COMPARTMENT/ MOUNTING CAGE WITH ALUMINUM BARRIER TO PROTECT COMPRESSOR FROM LOAD.
- 1/2" AIR HOSE REEL INSTALLED IN COMPRESSOR COMPARTMENT WITH ACCESS TO HOSE FROM RIGHT COMPARTMENT.
- AIR REGULATOR, OILER, WATER SEPARATOR IN RIGHT COMPARTMENT.
- 2 - HALOGEN WORK LIGHTS INSTALLED. 1 - LEFT AND 1 - RIGHT.
- AMBER STROBE INSTALLED, LEFT FRONT.
- BASE, MOUNT 23.2 CFM @ 175 PSI GAS ENGINE DRIVEN AIR COMPRESSOR SYSTEM (KOHLER 12.5 HP ENGINE)
- REMOTE MOUNTED 10 GALLON FUEL TANK INSTALLED IN COMPRESSOR COMPARTMENT FOR LONGER RUN TIME BETWEEN FILL UP'S. ALSO ELIMINATES POURING FUEL INTO TANK MOUNTED ON HOT ENGINE.
- AIR COMPRESSOR CONTROLS REMOTE MOUNTED TO RIGHT TOOL COMPARTMENT FOR EASY ACCESS.
- 35 - GALLON OVERHEAD AIR TANK.
- PAINTED ONE COLOR TO MATCH CAB.
- COMPARTMENT FLOORS ARE LINED WITH WOOD AND VINYL.
- ALL BOXES HAVE INTERIOR NIGHT LIGHTS.
- RAM JET COMES WITH A SET OF STACKABLE STORAGE BINS FOR SMALL PART STORAGE.
- EXHAUST ROUTING THROUGH TOP OF COMPRESSOR COMPARTMENT.

OPTIONAL EQUIPMENT

- SIDE BODY RACK EXTENSIONS THAT BOLT TO BACK OF STANDARD TOOL COMPARTMENTS AND FIT IN STAKE POCKETS ON PICKUP BED.
- ALSO INCLUDES A REAR CHAIN WITH BINDER.
- LEFT OR RIGHT SIDE STEEL TOOL COMPARTMENT WITH SWING DOWN DOORS. INSTALLED ON BED RAIL BEHIND STANDARD TOOL COMPARTMENT. THIS BOX IS BOLTED TO THE FRONT BOX AND BED SIDE RAIL WITH SUPPORT TO FLOOR OF BED.

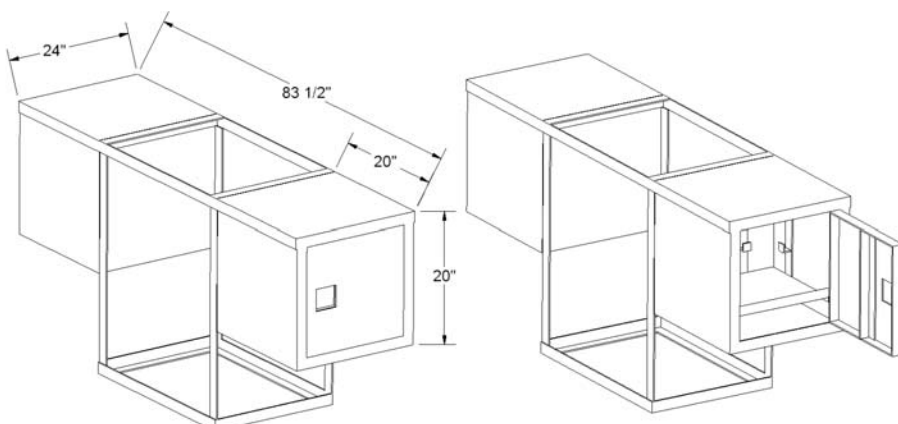

FLEET EQUIPMENT CORPORATION

The most trusted name in tire trucks.

800.631.0873

www.fectrucks.com